

Approval body for construction products
and types of construction

Bautechnisches Prüfamt

An institution established by the Federal and
Laender Governments



European Technical Assessment

ETA-15/0388
of 23 February 2016

English translation prepared by DIBt - Original version in German language

General Part

Technical Assessment Body issuing the
European Technical Assessment:

Deutsches Institut für Bautechnik

Trade name of the construction product

SPIT FIX Z XTREM torque-controlled expansion anchor

Product family
to which the construction product belongs

Torque controlled expansion anchor for use in concrete

Manufacturer

SPIT
ANCHORS & PINS INDUSTRIAL UNIT
150 route de Lyon
26501 BOURG LES VALENCE CEDEX
FRANKREICH

Manufacturing plant

Spit

This European Technical Assessment
contains

19 pages including 3 annexes

This European Technical Assessment is
issued in accordance with Regulation (EU)
No 305/2011, on the basis of

Guideline for European technical approval of "Metal
anchors for use in concrete", ETAG 001 Part 2: "Torque
controlled expansion anchors", April 2013,
used as European Assessment Document (EAD)
according to Article 66 Paragraph 3 of Regulation (EU)
No 305/2011.

This version replaces

ETA-15/0388 issued on 30 September 2015

The European Technical Assessment is issued by the Technical Assessment Body in its official language. Translations of this European Technical Assessment in other languages shall fully correspond to the original issued document and shall be identified as such.

Communication of this European Technical Assessment, including transmission by electronic means, shall be in full. However, partial reproduction may only be made with the written consent of the issuing Technical Assessment Body. Any partial reproduction shall be identified as such.

This European Technical Assessment may be withdrawn by the issuing Technical Assessment Body, in particular pursuant to information by the Commission in accordance with Article 25(3) of Regulation (EU) No 305/2011.

Specific Part

1 Technical description of the product

The SPIT FIX Z XTREM torque controlled expansion anchor is made of galvanised steel of sizes M8, M10, M12, M16 and M20 which is placed into a drilled hole and anchored by torque-controlled expansion.

The product description is given in Annex A.

2 Specification of the intended use in accordance with the applicable European Assessment Document

The performances given in Section 3 are only valid if the anchor is used in compliance with the specifications and conditions given in Annex B.

The verifications and assessment methods on which this European Technical Assessment is based lead to the assumption of a working life of the anchor of at least 50 years. The indications given on the working life cannot be interpreted as a guarantee given by the producer, but are to be regarded only as a means for choosing the right products in relation to the expected economically reasonable working life of the works.

3 Performance of the product and references to the methods used for its assessment

3.1 Mechanical resistance and stability (BWR 1)

| Essential characteristic | Performance |
|---|-------------------|
| Characteristic resistance for static and quasi static action and displacements | See Annex C1 – C3 |
| Characteristic resistance for seismic performance category C1 | See Annex C4 – C5 |
| Characteristic resistance for seismic performance category C2 and displacements | See Annex C6 – C7 |

3.2 Safety in case of fire (BWR 2)

| Essential characteristic | Performance |
|--------------------------|---|
| Reaction to fire | Anchorage satisfy requirements for Class A1 |
| Resistance to fire | See Annex C8 – C9 |

3.3 Safety in use (BWR 4)

The essential characteristics regarding Safety in use are included under the Basic Works Requirement Mechanical resistance and stability.

4 Assessment and verification of constancy of performance (AVCP) system applied, with reference to its legal base

In accordance with guideline for European technical approval ETAG 001, April 2013 used as European Assessment Document (EAD) according to Article 66 Paragraph 3 of Regulation (EU) No 305/2011 the applicable European legal act is: [96/582/EC]

The system to be applied is: 1

English translation prepared by DIBt

5 Technical details necessary for the implementation of the AVCP system, as provided for in the applicable European Assessment Document

Technical details necessary for the implementation of the AVCP system are laid down in the control plan deposited at Deutsches Institut für Bautechnik.

Issued in Berlin on 23 February 2016 by Deutsches Institut für Bautechnik

Andreas Kummerow
p. p. Head of Department

beglaubigt:
Baderschneider

Installed condition

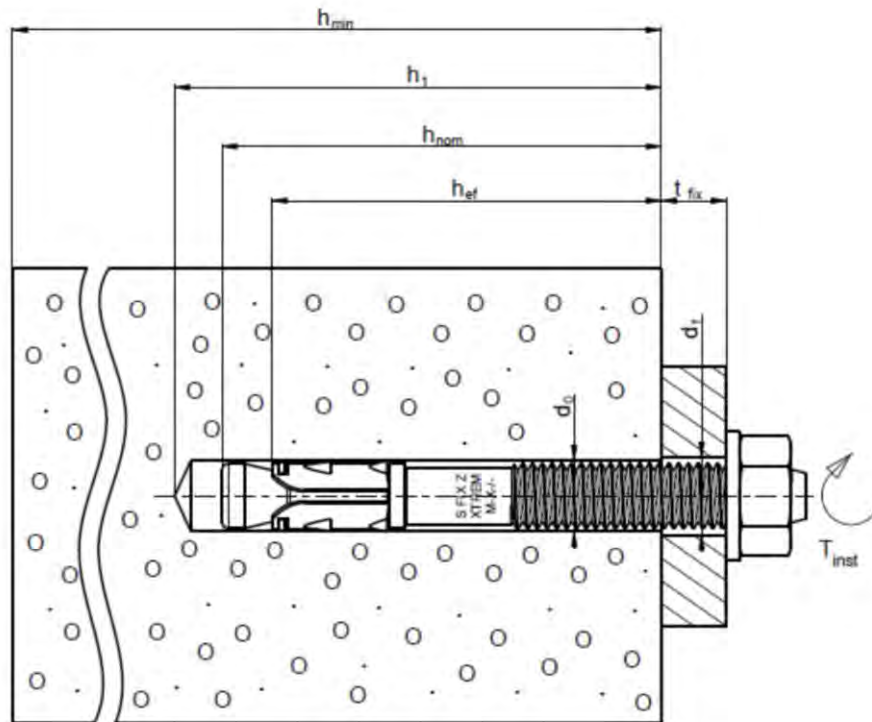

- h_{min} : Minimum thickness of concrete member
- h_1 : Depth of drilled hole to deepest point
- h_{nom} : Installation depth
- h_{eff} : Effective anchorage depth
- t_{fix} : thickness of fixture
- T_{inst} : Installation torque
- d_0 : Diameter of drilled hole
- d_f : Diameter of clearance hole in the fixture

SPIT FIX Z XTREM torque-controlled expansion anchor

Product description

Installed condition

Annex A1

Different parts of the anchor:

- Size M8

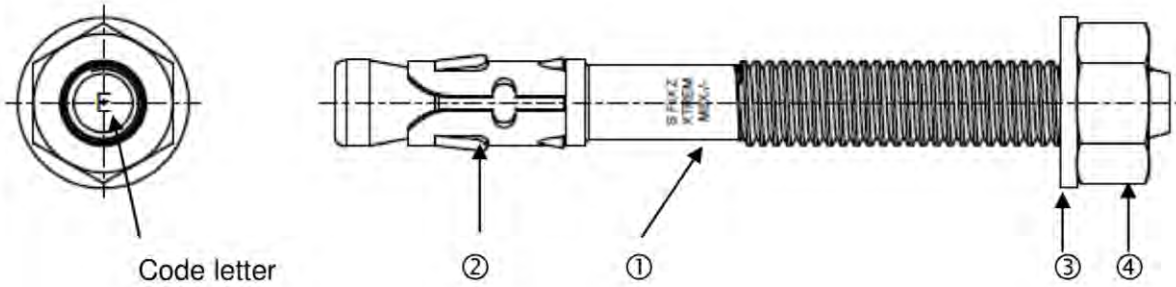

- Size M10 to M20

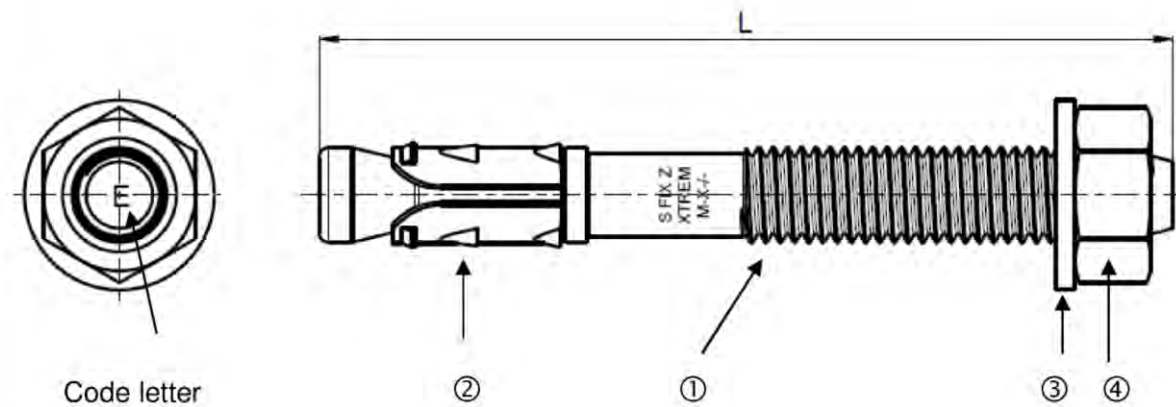

Designation of ① to ④, see Table 1, Annex A3.

Marking e.g.: **S FIX Z XTREM M12x115/20**
 S : Manufacturer SPIT
 FIX Z XTREM : Trade name
 M12 : Size of anchor
 115 : Length of the bolt
 20 : Maximum thickness of the fixture

SPIT FIX Z XTREM torque-controlled expansion anchor

Product description
Product and marking

Annex A2

Table A1: Materials

| Part (see Annex 2) | Designation | Material | Protection |
|-----------------------|-------------|---|---|
| ① | Bolt | Carbon steel | M8 : Zinc electroplated (>5µm) EN ISO 4042:1999 |
| | | | M10 –M20 : Zinc electroplated (>5µm) + anti-friction coating |
| ② | Clip | M8 : Stainless steel (1.4404) | Scouring |
| | | M10 – M20 : Carbon steel | Zinc electroplated (>5µm) EN ISO 4042:1999 |
| ③ | Washer | M8 : NF E 25514 | Zinc electroplated (>5µm) EN ISO 4042:1999 |
| | | M10-M20 : EN 10025:2004 or EN 10088-2:2005 | |
| ④ | Nut | Steel , strength class 8 DIN 267 or ISO 898-2:2012 | M8 - M10 : Zinc electroplated (>5µm) EN ISO 4042:1999 |
| | | | M12 –M20 : Zinc electroplated (>5µm) + anti-friction coating |

Table A2: Washers dimensions

| Anchor size | | M8 | M10 | M12 | M16 | M20 | |
|----------------|------------------------------|--------------------------------|-----|------|-----|-----|----|
| Washer sizes | | d ₁ [mm] inner Ø | 8,4 | 10,5 | 13 | 17 | 21 |
| Washer type | Narrow (standard version) | d ₂ [mm] outer Ø | 16 | 20 | 24 | 30 | 36 |
| | Broad | d ₂ [mm] outer Ø | 18 | 22 | 32 | 40 | 50 |
| | X-broad | d ₂ [mm] outer Ø | 22 | 27 | 40 | 50 | 60 |

SPIT FIX Z XTREM torque-controlled expansion anchor

Product description

Material, Washer dimensions

Annex A3

Specifications of intended use

Anchorage subject to:

- Static and quasi-static loads: M8 to M20
- Seismic action for performance category C1: M8 to M20
- Seismic action for performance category C2: M10 to M20
- Fire exposure: M8 to M20

Base materials:

- Reinforced or unreinforced normal weight concrete to EN 206-1:2000.
- Strength classes C20/25 to C50/60 according to EN 206-1:2000.
- Cracked and non-cracked concrete

Use conditions (Environmental conditions):

- Structures subject to dry indoor conditions.

Design:

- Anchorages are designed under the responsibility of an engineer experienced in anchorages and concrete work.
- Verifiable calculation notes and drawings are prepared taking account of the loads to be anchored. The position of the anchor is indicated on the design drawings (e. g. position of the anchor relative to reinforcement or to supports, etc.).
- Anchorages under static or quasi-static actions are designed in accordance with:
 - ETAG 001, Annex C, design method A, Edition August 2010 or
 - CEN/TS 1992-4:2009, design method A
- Anchorages under seismic action are designed in accordance with:
 - EOTA Technical Report TR 045, Edition February 2013 (Seismic performance category C1).
 - Anchorages shall be positioned outside of critical regions (e.g. plastic hinges) of the concrete structure.
- Fastenings in stand-off installation or with a grout layer are not allowed.
- Anchorages under fire exposure are designed in accordance with:
 - ETAG 001, Annex C, design method A, Edition August 2010 and EOTA Technical Report TR 020, Edition May 2004 or
 - CEN/TS 1992-4:2009, Annex D
 - In case of requirements to resistance to fire local spalling of the concrete cover must be avoided.

Installation:

- Anchor installation carried out by appropriately qualified personnel and under the supervision of the person responsible for technical matters of the site.
- Hole drilling by hammer drill mode
- In case of aborted hole: new drilling at a minimum distance away of twice the depth of the aborted hole or smaller distance if the aborted hole is filled with high strength mortar and if under shear or oblique tension load it is not the direction of the load application.

SPIT FIX Z XTREM torque-controlled expansion anchor

Intended used
Specifications

Annex B1

Table B1: Anchor dimensions and Installation parameters

| Spit FIX Z XTREM | L [mm] | Code letter | t _{fix,max} [mm] | d _f [mm] | h _{min} [mm] | h _{nom} [mm] | h _{ef} [mm] | d ₀ [mm] | h ₁ [mm] | T _{inst} [Nm] |
|------------------|-----------|----------------|------------------------------|------------------------|--------------------------|--------------------------|-------------------------|------------------------|------------------------|---------------------------|
| | (0) | | (1) | (2) | (3) | (4) | (5) | (6) | (7) | (8) |
| 8x65/5 | 68 | B | 5 | 9 | 100 | 55 | 46 | 8 | 65 | 20 |
| 8x75/15 | 78 | D | 15 | | | | | | | |
| 8x90/30 | 93 | E | 30 | | | | | | | |
| 8x120/60 | 123 | G | 60 | | | | | | | |
| 8x130/70 | 133 | H | 70 | | | | | | | |
| 8x140/80 | 143 | I | 80 | | | | | | | |
| 10x85/5 | 85 | D | 5 | 12 | 120 | 68 | 60 | 10 | 75 | 45 |
| 10x90/10 | 90 | E | 10 | | | | | | | |
| 10x100/20 | 100 | F | 20 | | | | | | | |
| 10x120/40 | 120 | G | 40 | | | | | | | |
| 10x140/60 | 140 | I | 60 | | | | | | | |
| 10x160/80 | 160 | - | 80 | | | | | | | |
| 12x100/5 | 100 | E | 5 | 14 | 140 | 80 | 70 | 12 | 90 | 60 |
| 12x105/10 | 105 | F | 10 | | | | | | | |
| 12x115/20 | 115 | G | 20 | | | | | | | |
| 12x135/40 | 135 | I | 40 | | | | | | | |
| 12x155/60 | 155 | J | 60 | | | | | | | |
| 12x180/84 | 180 | L | 85 | | | | | | | |
| 16x145/25 | 142.5 | I | 25 | 18 | 170 | 98 | 85 | 16 | 110 | 110 |
| 16x170/50 | 167.5 | K | 50 | | | | | | | |
| 16x180/60 | 177.5 | L | 60 | | | | | | | |
| 20x170/30 | 168 | K | 30 | 22 | 200 | 113 | 100 | 20 | 130 | 160 |
| 20x200/60 | 198 | M | 60 | | | | | | | |
| 20x220/80 | 218 | O | 80 | | | | | | | |

(0) Total length of the bolt [mm]

(1) Maximum thickness of the fixture, t_{fix,max} [mm]

(2) Diameter of clearance hole in the fixture, d_f [mm]

(3) Minimum thickness of concrete member, h_{min} [mm]

(4) Minimum installation depth, h_{nom} [mm]

(5) Effective anchorage depth, h_{ef} [mm]

(6) Diameter of drilled hole, d₀ [mm]

(7) Depth of drilled hole to deepest point, h₁ [mm]

(8) Required torque moment, T_{inst} [Nm]

Dimensions illustrated in Annex A1:Installation

Table B2: Minimum member thickness, spacing and edge distance

| Anchor size | | M8 | M10 | M12 | M16 | M20 | |
|---|------------------|------|-----|-----|-----|-----|-----|
| Minimum thickness of concrete member h _{min} | [mm] | 100 | 120 | 140 | 170 | 200 | |
| Cracked concrete | | | | | | | |
| Minimum spacing | S _{min} | [mm] | 50 | 55 | 60 | 90 | 100 |
| | for C ≥ | [mm] | 65 | 70 | 100 | 100 | 120 |
| Minimum edge distance | C _{min} | [mm] | 50 | 55 | 60 | 80 | 100 |
| | for S ≥ | [mm] | 75 | 90 | 145 | 110 | 130 |
| Non-cracked concrete | | | | | | | |
| Minimum spacing | S _{min} | [mm] | 50 | 55 | 60 | 90 | 130 |
| | for C ≥ | [mm] | 90 | 70 | 100 | 105 | 120 |
| Minimum edge distance | C _{min} | [mm] | 50 | 60 | 60 | 90 | 100 |
| | for S ≥ | [mm] | 75 | 120 | 145 | 140 | 160 |

SPIT FIX Z XTREM torque-controlled expansion anchor



Intended use

Anchor dimensions and Installation parameters

Minimum member thickness, spacing and edge distance

Annex B2

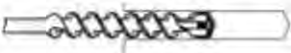
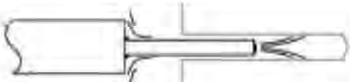
Installation instruction

| | |
|---|---|
|  | <p>Drill hole perpendicular to concrete surface, positioning of the drill holes without damaging the reinforcement. In case of aborted hole : new drilling at a minimum distance away of twice the depth of the aborted hole or smaller distance if the aborted drill hole is filled with high strength mortar and if under shear or oblique tension load it is not in the direction of the load application.</p> |
|  | <p>Blow out dust</p> |
|  | <p>Drive in anchor, such that h_{ef} is met. This is ensured, if the thickness of fixture is not greater than the maximum thickness of fixture marked on the anchor according to Annex B2.</p> |
|  | <p>Apply installation torque T_{inst} by using calibrated torque wrench.</p> |

SPIT FIX Z XTREM torque-controlled expansion anchor

Intended use
Installation instructions

Annex B3

**Table C1: Characteristic values of tension resistance for static and quasi-static actions:
Design according to ETAG001, Annex C or CEN/TS 1992-4**

| Anchor size | | | M8 | M10 | M12 | M16 | M20 |
|--|----------------------------|--------|------|------|------|-------|------|
| Steel failure | | | | | | | |
| Characteristic resistance | $N_{Rk,s}$ | [kN] | 22,1 | 29,3 | 38,2 | 64,7 | 99,1 |
| Partial safety factor | $\gamma_{Ms}^{1)}$ | - | 1,4 | 1,48 | 1,48 | 1,48 | 1,5 |
| Pull-out failure | | | | | | | |
| Effective anchorage depth | h_{ef} | [mm] | 46 | 60 | 70 | 85 | 100 |
| Characteristic resistance in non-cracked concrete C20/25 | $N_{Rk,p}$ | [kN] | 9 | 20 | 30 | 40 | 2) |
| Characteristic resistance in cracked concrete C20/25 | $N_{Rk,p}$ | [kN] | 5 | 9 | 16 | 20 | 30 |
| Partial safety factor | $\gamma_2 = \gamma_{inst}$ | - | 1,0 | | | | |
| Increasing factor for $N_{Rk,p}$ | ψ_c | C25/30 | 1,10 | 1,04 | 1,04 | 1,07 | 1,10 |
| | | C30/37 | 1,22 | 1,08 | 1,08 | 1,15 | 1,22 |
| | | C35/45 | 1,34 | 1,12 | 1,12 | 1,23 | 1,34 |
| | | C40/50 | 1,41 | 1,15 | 1,15 | 1,27 | 1,41 |
| | | C45/55 | 1,48 | 1,17 | 1,17 | 1,32 | 1,48 |
| | | C50/60 | 1,55 | 1,19 | 1,19 | 1,36 | 1,55 |
| Concrete cone failure and splitting failure ³⁾ | | | | | | | |
| Effective anchorage depth | h_{ef} | [mm] | 46 | 60 | 70 | 85 | 100 |
| Factor for non-cracked concrete | k_{ucr} | - | 10,1 | | | | |
| Factor for cracked concrete | k_{cr} | - | 7,2 | | | | |
| Spacing | $s_{cr,N}$ | [mm] | 138 | 180 | 210 | 255 | 300 |
| | $s_{cr,sp}$ | [mm] | 276 | 226 | 252 | 306 | 370 |
| Edge distance | $c_{cr,N}$ | [mm] | 69 | 90 | 105 | 127,5 | 150 |
| | $c_{cr,sp}$ | [mm] | 138 | 113 | 126 | 153 | 185 |
| Partial safety factor | $\gamma_2 = \gamma_{inst}$ | - | 1,0 | | | | |

1) In absence of other national regulation,

2) The pull-out failure mode is not decisive for design,

3) To give proof of splitting failure due to loading use the smaller value of $N_{Rk,p}$ and $N_{Rk,c}^0$

SPIT FIX Z XTREM torque-controlled expansion anchor

Performances

Characteristic values of tension resistance for static and quasi-static actions

Annex C1

**Table C2: Characteristic values of shear resistance for static and quasi-static actions:
Design according to ETAG001, Annex C or CEN/TS 1992-4**

| Anchor size | | | M8 | M10 | M12 | M16 | M20 |
|--|-----------------------------|-------|------|------|------|-------|-------|
| Steel failure without lever arm | | | | | | | |
| Characteristic resistance | $V_{Rk,s}$ | [kN] | 13,7 | 16 | 23 | 45 | 61 |
| Partial safety factor | γ_{Ms} ¹⁾ | - | 1,5 | 1,27 | 1,27 | 1,25 | 1,50 |
| Steel failure with lever arm | | | | | | | |
| Characteristic resistance | $M_{Rk,s}^0$ | [N,m] | 28 | 52,8 | 91,3 | 194,0 | 315,7 |
| Partial safety factor | γ_{Ms} ¹⁾ | - | 1,5 | 1,27 | 1,27 | 1,25 | 1,50 |
| Concrete pry-out failure | | | | | | | |
| k Factor | $k = k_3$ | - | 1 | 2 | 2 | 2 | 2 |
| Partial safety factor | $\gamma_2 = \gamma_{inst}$ | - | 1,0 | | | | |
| Concrete edge failure | | | | | | | |
| Effective length of anchor under shear loading | l_f | [mm] | 46 | 60 | 70 | 85 | 100 |
| Outside diameter of anchor | d_{nom} | [mm] | 8 | 10 | 12 | 16 | 20 |
| Partial safety factor | $\gamma_2 = \gamma_{inst}$ | - | 1,0 | | | | |

¹⁾ In absence of other national regulation,

SPIT FIX Z XTREM torque-controlled expansion anchor

Performances

Characteristic values of shear resistance for static and quasi-static actions

Annex C2

Table C3: Displacement under tension loads for static and quasi-static actions

| Anchor size | | | M8 | M10 | M12 | M16 | M20 |
|---|--------------------|------|-----|-----|------|------|------|
| Effective anchorage depth | h_{ef} | [mm] | 46 | 60 | 70 | 85 | 100 |
| Tension load in cracked concrete C20/25 | N | [kN] | 1,4 | 4,3 | 7,6 | 9,5 | 14,3 |
| Displacements in cracked concrete under tension | δ_{N0} | [mm] | 0,3 | 0,4 | 0,4 | 0,4 | 0,4 |
| | $\delta_{N\infty}$ | [mm] | 1,3 | 1,6 | 1,7 | 1,7 | 1,7 |
| Tension load in non-cracked concrete C20/25 | N | [kN] | 3,6 | 9,5 | 14,3 | 19,0 | 23,8 |
| Displacements in non-cracked concrete under tension | δ_{N0} | [mm] | 0,1 | 0,4 | 0,4 | 0,4 | 0,4 |
| | $\delta_{N\infty}$ | [mm] | 1,3 | 1,6 | 1,7 | 1,7 | 1,7 |

Table C4: Displacement under shear loads for static and quasi-static actions

| Anchor size | | | M8 | M10 | M12 | M16 | M20 |
|---------------------------|--------------------|------|-----|-----|------|------|------|
| Effective anchorage depth | h_{ef} | [mm] | 46 | 60 | 70 | 85 | 100 |
| Shear load | V | [kN] | 6,5 | 9 | 12,9 | 25,4 | 34,5 |
| Displacements | δ_{V0} | [mm] | 2,0 | 1,5 | 1,5 | 1,5 | 1,5 |
| | $\delta_{V\infty}$ | [mm] | 3,0 | 2,3 | 2,3 | 2,3 | 2,3 |

SPIT FIX Z XTREM torque-controlled expansion anchor

Performances

Displacements under tension and shear loads for static and quasi-static actions

Annex C3

Table C5 : Characteristic tension resistance for seismic loading, performance category C1: Design according to TR045

The definition of seismic performance category C1 is given in TR045.

| Anchor size | | | M8 | M10 | M12 | M16 | M20 |
|--|--------------------------------|------|------|------|------|------|------|
| Steel failure | | | | | | | |
| Characteristic resistance | $N_{Rk,s,C1}$ | [kN] | 18,5 | 29,3 | 38,2 | 64,7 | 99,1 |
| Partial safety factor | $\gamma_{Ms,C1}$ ¹⁾ | - | 1,4 | 1,48 | 1,48 | 1,48 | 1,5 |
| Pull-out failure | | | | | | | |
| Characteristic resistance | $N_{Rk,p,C1}$ | [kN] | 4,7 | 7,4 | 16,0 | 20,0 | 30,0 |
| Partial safety factor | $\gamma_{2,C1}$ | - | 1,0 | | | | |
| Concrete cone failure ²⁾ | | | | | | | |
| Partial safety factor | $\gamma_{2,C1}$ | - | 1,0 | | | | |
| Splitting failure ²⁾ | | | | | | | |
| Partial safety factor | $\gamma_{2,C1}$ | - | 1,0 | | | | |

1) In absence of other national regulation,

2) For concrete cone failure and splitting failure see TR045 - §5.6.2

SPIT FIX Z XTREM torque-controlled expansion anchor

Performances

Characteristic tension resistance for seismic loading, performance category C1

Annex C4

**Table C6 : Characteristic shear resistance for seismic loading, performance category C1:
Design according to TR045**

The definition of seismic performance category C1 is given in TR045 §5.2,

| Anchor size | | | M8 | M10 | M12 | M16 | M20 |
|--|-----------------------|------|------|------|------|------|------|
| Steel failure | | | | | | | |
| Characteristic resistance | $V_{Rk,s,C1}$ | [kN] | 6 | 16 | 23 | 45 | 61 |
| Partial safety factor | $\gamma_{Ms,C1}^{1)}$ | - | 1,50 | 1,27 | 1,27 | 1,25 | 1,50 |
| Concrete pryout failure ²⁾ | | | | | | | |
| Partial safety factor | $\gamma_{2,C1}$ | - | 1,0 | | | | |
| Concrete edge failure ²⁾ | | | | | | | |
| Partial safety factor | $\gamma_{2,C1}$ | - | 1,0 | | | | |

1) In absence of other national regulation,

2) For pryout failure and concrete edge failure see TR045 - §5.6.2

SPIT FIX Z XTREM torque-controlled expansion anchor

Performances

Characteristic shear resistance for seismic loading, performance category C1

Annex C5

Table C7 : Characteristic tension resistance for seismic loading, performance category C2: Design according to TR045

The definition of seismic performance category C2 is given in TR045 §5.2.

| Anchor size | | | M10 | M12 | M16 | M20 |
|--|--------------------------------|------|------|------|------|------|
| Steel failure | | | | | | |
| Characteristic resistance | $N_{Rk,s,C2}$ | [kN] | 29,3 | 38,2 | 64,7 | 99,1 |
| Partial safety factor | $\gamma_{Ms,C2}$ ¹⁾ | - | 1,48 | 1,48 | 1,48 | 1,5 |
| Pull-out failure | | | | | | |
| Characteristic resistance | $N_{Rk,p,C2}$ | [kN] | 2,8 | 6,0 | 18,0 | 25,6 |
| Partial safety factor | $\gamma_{2,C2}$ | - | 1,0 | | | |
| Concrete cone failure ²⁾ | | | | | | |
| Partial safety factor | $\gamma_{2,C2}$ | - | 1,0 | | | |
| Splitting failure ²⁾ | | | | | | |
| Partial safety factor | $\gamma_{2,C2}$ | - | 1,0 | | | |

1) In absence of other national regulation,

2) For concrete cone failure and splitting failure see TR045 - §5.6.2

Table C8 : Displacement under tension loads for seismic loading, performance category C2

| Anchor size | | | M10 | M12 | M16 | M20 |
|------------------|-------------------------|------|-----|-----|-----|------|
| Displacement DLS | $\delta_{N,seis (DLS)}$ | [mm] | 3,1 | 2,1 | 5,1 | 4,97 |
| Displacement ULS | $\delta_{N,seis (ULS)}$ | [mm] | 14 | 7 | 14 | 13 |

SPIT FIX Z XTREM torque-controlled expansion anchor

Performances

Characteristic tension resistance, and displacements under tension loads for seismic loading, performance category C2

Annex C6

Table C9 : Characteristic shear resistance for seismic loading, performance category C2 Design according to TR045

The definition of seismic performance category C2 is given in TR045 §5.2.

| Anchor size | | | M10 | M12 | M16 | M20 |
|--|-----------------------|------|------|------|------|------|
| Steel failure | | | | | | |
| Characteristic resistance | $V_{Rk,s,C2}$ | [kN] | 9,7 | 14,0 | 33,9 | 44,7 |
| Partial safety factor | $\gamma_{Ms,C2}^{1)}$ | - | 1,27 | 1,27 | 1,25 | 1,50 |
| Concrete pryout failure ²⁾ | | | | | | |
| Partial safety factor | $\gamma_{2,C2}$ | - | 1,0 | | | |
| Concrete edge failure ²⁾ | | | | | | |
| Partial safety factor | $\gamma_{2,C2}$ | - | 1,0 | | | |

1) In absence of other national regulation,

2) For concrete pryout failure and concrete edge failure see TR045 - §5.6.2,

Table C10 : Displacement under shear loads for seismic loading, performance category C2

| Anchor size | | | M10 | M12 | M16 | M20 |
|------------------|-------------------------|------|-----|-----|-----|-----|
| Displacement DLS | $\delta_{V,seis} (DLS)$ | [mm] | 3,8 | 4,1 | 4,7 | 4,9 |
| Displacement ULS | $\delta_{V,seis} (ULS)$ | [mm] | 6,0 | 6,3 | 9,0 | 9,0 |

SPIT FIX Z XTREM torque-controlled expansion anchor

Performances

Characteristic shear resistance for seismic loading, performance category C2

Annex C7

Table C11 : Characteristic tension resistance under fire exposure in cracked and non-cracked concrete : design according to TR020 and ETAG 001, Annex C or CEN/TS 1992-4 Annex D,

| Anchor size | | | | M8 | M10 | M12 | M16 | M20 |
|---|------|----------------|------|---|-----|-----|------|------|
| Steel failure | | | | | | | | |
| Characteristic resistance | R30 | $N_{Rk,s,fi}$ | [kN] | 0.9 | 2,8 | 3,6 | 6,6 | 10,4 |
| | R60 | $N_{Rk,s,fi}$ | [kN] | 0.7 | 2,3 | 3,1 | 5,7 | 9,0 |
| | R90 | $N_{Rk,s,fi}$ | [kN] | 0.5 | 1,8 | 2,6 | 4,9 | 7,6 |
| | R120 | $N_{Rk,s,fi}$ | [kN] | 0.4 | 1,6 | 2,4 | 4,4 | 6,9 |
| Pullout failure | | | | | | | | |
| Characteristic resistance in concrete \geq C20/25 | R30 | $N_{Rk,p,fi}$ | [kN] | 1,3 | 2,3 | 4,0 | 5,0 | 7,5 |
| | R60 | $N_{Rk,p,fi}$ | [kN] | 1,3 | 2,3 | 4,0 | 5,0 | 7,5 |
| | R90 | $N_{Rk,p,fi}$ | [kN] | 1,3 | 2,3 | 4,0 | 5,0 | 7,5 |
| | R120 | $N_{Rk,p,fi}$ | [kN] | 1,0 | 1,8 | 3,2 | 4,0 | 6,0 |
| Concrete cone failure | | | | | | | | |
| Characteristic resistance in concrete \geq C20/25 | R30 | $N^0_{Rkc,fi}$ | [kN] | 2,6 | 5,0 | 7,4 | 12,0 | 18,0 |
| | R60 | $N^0_{Rkc,fi}$ | [kN] | 2,6 | 5,0 | 7,4 | 12,0 | 18,0 |
| | R90 | $N^0_{Rkc,fi}$ | [kN] | 2,6 | 5,0 | 7,4 | 12,0 | 18,0 |
| | R120 | $N^0_{Rkc,fi}$ | [kN] | 2,1 | 4,0 | 5,9 | 9,6 | 14,4 |
| Spacing | - | $s_{cr,N}$ | [mm] | 4 x h_{ef} | | | | |
| | - | s_{min} | [mm] | 50 | 55 | 100 | 90 | 100 |
| Edge distance | - | $c_{cr,N}$ | [mm] | 2 x h_{ef} | | | | |
| | - | c_{min} | [mm] | $c_{min} = 2 \times h_{ef}$. if the fire attack is from more than one side, the edge distance of the anchor has to be 300 mm and 2 x h_{ef} | | | | |

In absence of other national regulations the partial safety factor for resistance under fire exposure $\gamma_{M,fi} = 1,0$ is recommended

SPIT FIX Z XTREM torque-controlled expansion anchor

Performances

Characteristic tension resistance under fire exposure in cracked and non-cracked concrete

Annex C8

Table C12 : Characteristic shear resistance under fire exposure in cracked and non-cracked concrete C20/25 to C50/60 : design according to TR020 and ETAG 001, Annex C or CEN/TS 1992-4 Annex D,

| Anchor size | | | | M8 | M10 | M12 | M16 | M20 |
|---|-----------|-----------------|------|-----|-----|-----|------|------|
| Steel failure without level arm | | | | | | | | |
| Characteristic resistance | R30 | $V_{Rk,s,fi}$ | [kN] | 0.9 | 1,4 | 1,8 | 3,3 | 5,2 |
| | R60 | $V_{Rk,s,fi}$ | [kN] | 0.7 | 1,1 | 1,5 | 2,9 | 4,5 |
| | R90 | $V_{Rk,s,fi}$ | [kN] | 0.5 | 0,9 | 1,3 | 2,4 | 3,8 |
| | R120 | $V_{Rk,s,fi}$ | [kN] | 0.4 | 0,8 | 1,2 | 2,2 | 3,4 |
| Steel failure with level arm | | | | | | | | |
| Characteristic resistance | R30 | $M^0_{Rk,s,fi}$ | [Nm] | 0.9 | 3,5 | 5,5 | 14,1 | 27,5 |
| | R60 | $M^0_{Rk,s,fi}$ | [Nm] | 0.7 | 2,9 | 4,8 | 12,2 | 23,8 |
| | R90 | $M^0_{Rk,s,fi}$ | [Nm] | 0.5 | 2,3 | 4,0 | 10,3 | 20,1 |
| | R120 | $M^0_{Rk,s,fi}$ | [Nm] | 0.4 | 2,0 | 3,7 | 9,3 | 18,2 |
| Concrete pryout failure | | | | | | | | |
| k- Factor | $k = k_3$ | - | 1 | 2 | 2 | 2 | 2 | 2 |
| The above values of k factor and the relevant values of $N_{Rk,c,fi}$ given in Annex C8 Table C11 have to be considered in the design | | | | | | | | |
| Concrete edge failure | | | | | | | | |
| The characteristic resistance $V^0_{Rk,c,fi}$ in C20/25 to C50/60 concrete is determined by : $V^0_{Rk,c,fi} = 0,25 \times V^0_{Rk,c}$ ($\leq R90$) and $V^0_{Rk,c,fi} = 0,2 \times V^0_{Rk,c}$ (R120) with $V^0_{Rk,c}$ initial value of the characteristic resistance in cracked concrete C20/25 under normal temperature according to ETAG 001; Annex C, §5.2.3.4. | | | | | | | | |

In absence of other national regulations the partial safety factor for resistance under fire exposure $\gamma_{M,fi} = 1,0$ is recommended

SPIT FIX Z XTREM torque-controlled expansion anchor

Performances

Characteristic shear resistance under fire exposure in cracked and non-cracked concrete

Annex C9